

# CATALOGUE

## VOLUME CONTROL DAMPER



**AL MABANI**  
AL UMUMIYAH



[saudi@almabani.net](mailto:saudi@almabani.net)



+966 54 448 2805  
+966 56 603 6992



L: RMFB5067, 14548 Riyadh - KSA14548, Riyadh, KSA  
E-mail: [saudi@almabani.net](mailto:saudi@almabani.net) \* Website: [www.almabani.net](http://www.almabani.net)



**General**

Commercial Control Dampers are used in buildings to regulate the flow of air in an HVAC system. They can be used in intake, exhaust, or mixed air applications. There are two categories of control dampers:

- Balancing
- Volume Control

The damper comes with manual hand quadrant or actuators for the blade adjustment.

The volume dampers are available in galvanized steel as standard. Stainless steel and aluminum option available.



**Features**

Al Mabani standard and low leakage control dampers are designed for economical and reliable air volume control and coming with the following features

**Frame options**

There are various framing option available to suit the existing site condition.

Channel ( Standard ) : Allows damper to be insert mounted into an opening or duct

Single Flange or Single reverse flange-Can be insert mounted or directly mounted to the wall or mating surface such as plenum wall

Double Flange –Both side

Slip on flange - To match the duct connection with flanges

Drive Cleat Damper-For smaller size damper, drive cleats damper enable the easy installation with the duct

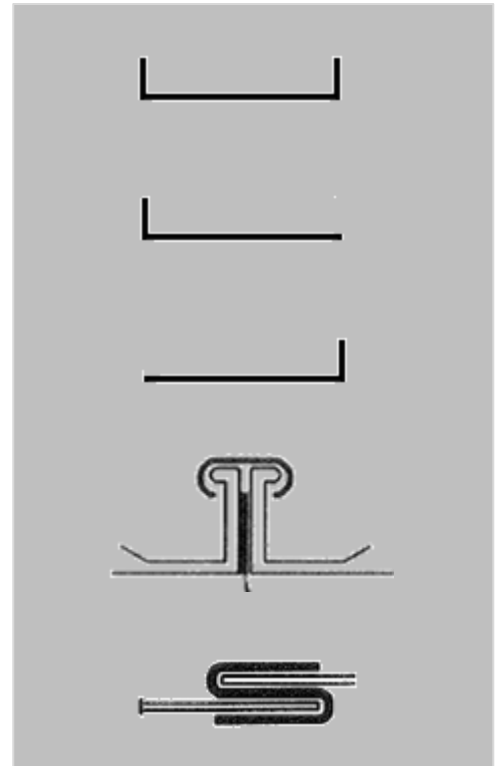

### DAMPER BLADES

Fabricated from a single thickness galvanized steel or stainless steel

- Three V-type grooves running the full length of the blade to increase strength
- Low to medium velocity and pressure applications

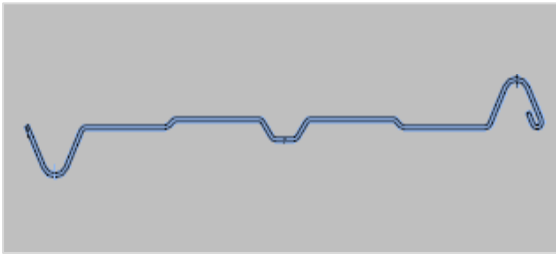

Constructed of heavy gauge extruded aluminum

- This blade design results in lower resistance to airflow and increased strength
- High velocity and pressure applications

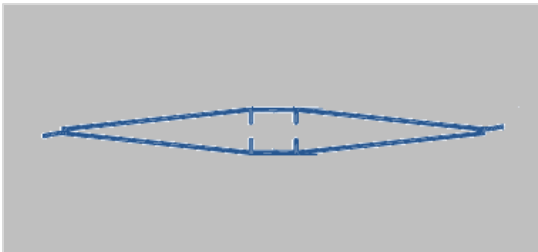

• Constructed of double-skin galvanized steel or stainless steel

- This blade design results in lower resistance to airflow and increased strength
- High velocity and pressure applications

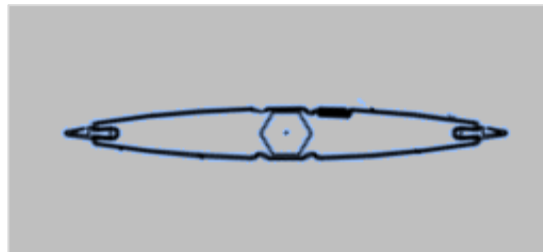

**BLADE OPERATION**

Parallel Versus Opposed Blade Operation Al Mabani control dampers are offered with either parallel or opposed blades. Each style has distinguishing characteristics in regard to the type of operation required.

**PARALLEL BLADE OPERATION**

This configuration requires the damper blades to rotate in the same direction, parallel to one another. Parallel blade orientation is typically used when the damper operates in two positions, open or closed.

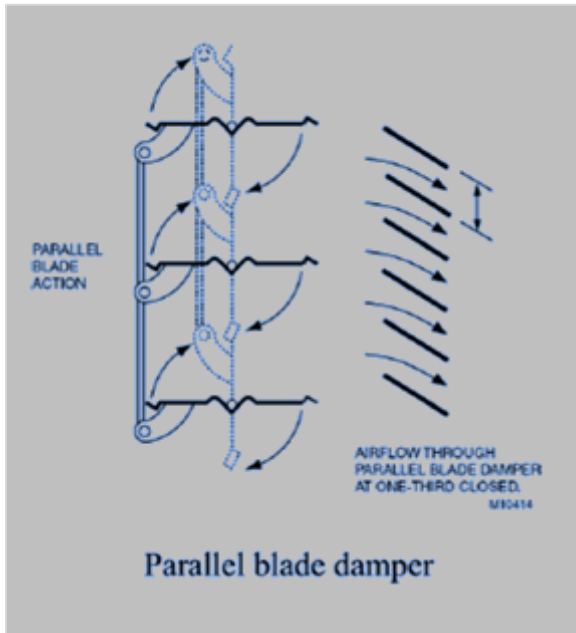

**OPPOSED BLADE OPERATION**

Adjacent damper blades rotate opposite one another under opposed blade configuration. Opposed blade configuration is typically used on dampers that modulate airflow.

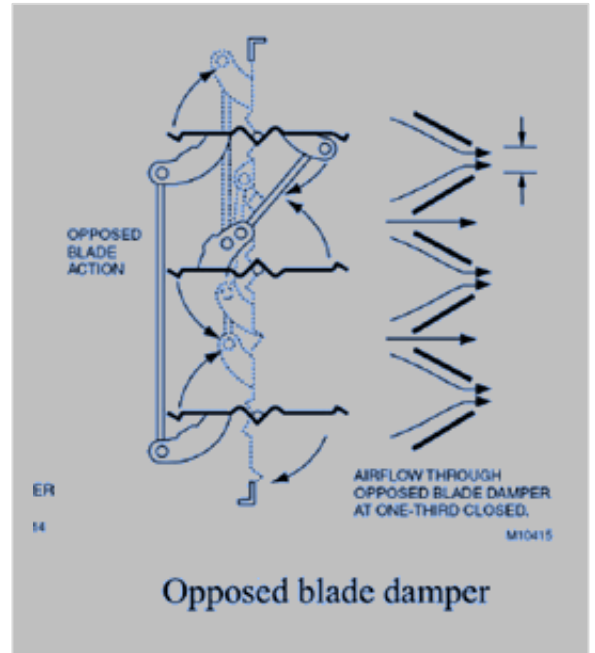

**BEARING  
NYLON BUSHING**

Al Mabani Nylon Bushing are designed to create an air tight seal when supporting damper rod/bearings. Functionally Rated for intermittent high temperatures of 215°F/102°C.

Available in two different sizes

**BRASS BUSHING**

Brass bushing is used for the high temperature application.

Available in two different size

**LINKAGE**

Al Mabani control dampers have blade linkages concealed in the frame to prevent additional pressure drop and unwanted noise.

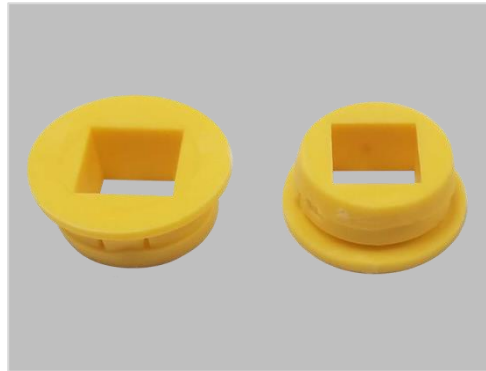

**3 V BLADE DAMPER**  
**STANDARD CONSTRUCTION**

**FRAME:**  
150mm x 25mm x 1 mm(20 G )  
galvanized steel formed channel for  
flange connection.

**BLADES:**  
Roll formed triple V groove blade (3V  
blades )

**FINISH:**  
Mill galvanized.

**LINKAGE:**  
Side linkage concealed in frame for  
parallel and opposed blade operation.

**CASE BEARING:**  
Nylon bushing for smooth and rattle free  
operation.  
Brass bushing optional

**CONTROL SHAFT:**  
10mmx10mm & 12mmx12mm square  
zinc plated mild steel.

**MINIMUM & MAXIMUM SINGLE SECTION  
SIZE:**  
100 x 100mm minimum & 1200 x 1800mm  
maximum.

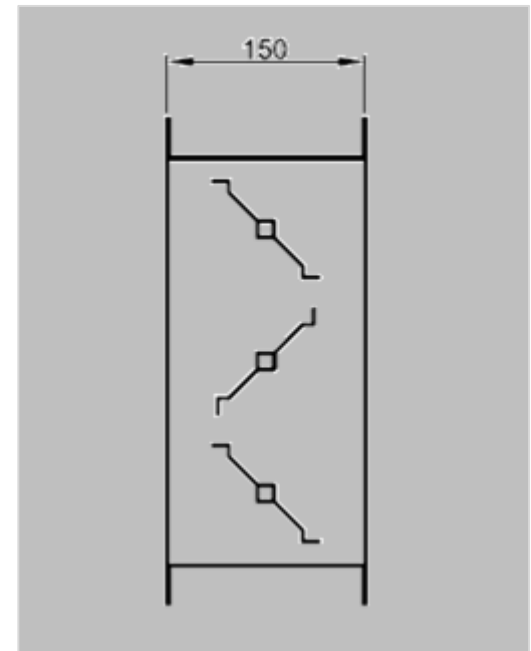

## ALUMINUM AEROFOIL DAMPER

### STANDARD CONSTRUCTION

#### FRAME:

150mm x 25mm x 1 mm(20 G) galvanized steel formed channel for flange connection.

#### BLADES:

150 mm max. width, extruded aluminum aero foil type blades.

#### FINISH:

Mill galvanized.

#### LINKAGE:

Side linkage concealed in frame for parallel and opposed blade operation.

#### CASE BEARING:

Nylon bushing for smooth and rattle free operation.  
Brass bushing optional

#### CONTROL SHAFT:

10mmx10mm & 12mmx12mm square zinc plated mild steel.

#### MINIMUM & MAXIMUM SINGLE SECTION SIZE:

100 x 100mm minimum & 1200 x 1800mm maximum.

All manual dampers available with motorized option with Honeywell actuator

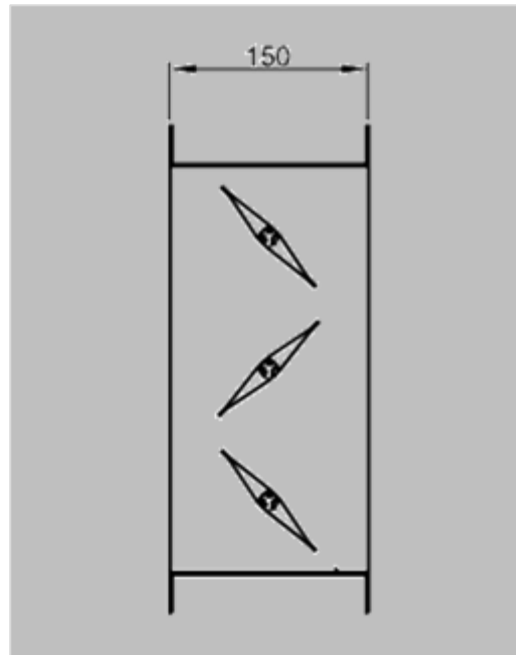

### VOLUME DAMPER FLANGE TYPE

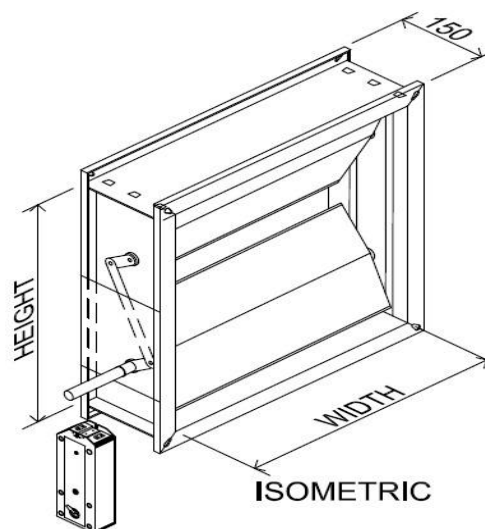



## DAMPER WITH SLIP ON FLANGE

### STANDARD CONSTRUCTION

#### FRAME:

150mm x 25mm x 1 mm(20 G) galvanized steel formed channel for flange connection.

#### BLADES:

150 mm max. width, extruded aluminum aero foil type blades.

#### FINISH:

Mill galvanized.

#### LINKAGE:

Side linkage concealed in frame for parallel and opposed blade operation.

#### CASE BEARING:

Nylon bushing for smooth and rattle free operation.

Brass bushing optional

#### CONTROL SHAFT:

10mmx10mm & 12mmx12mm square zinc plated mild steel.

#### MINIMUM & MAXIMUM SINGLE SECTION

##### SIZE:

100 x 100mm minimum & 1200 x 1800mm maximum.

All manual dampers available with motorized option with Honeywell actuator

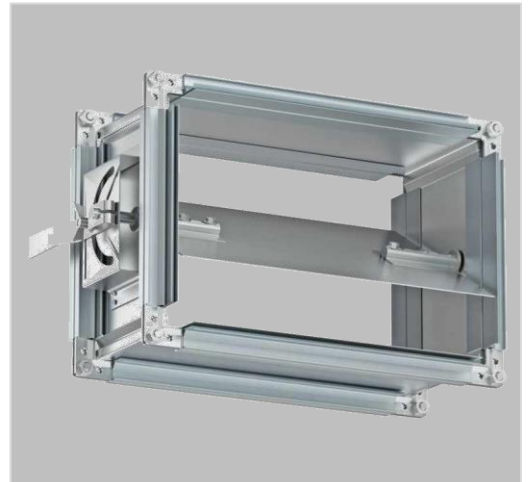



## GI AEROFOIL DAMPER

### STANDARD CONSTRUCTION

#### FRAME:

150mm x 25mm x 1 mm(20 G) galvanized steel formed channel for flange connection.

#### BLADES:

150 mm max. width, extruded roll formed GI aero foil blades.

#### FINISH:

Mill galvanized.

#### LINKAGE:

Side linkage concealed in frame for parallel and opposed blade operation.

#### CASE BEARING:

Nylon bushing for smooth and rattle free operation.

Brass bushing optional

#### CONTROL SHAFT:

10mmx10mm & 12mmx12mm square zinc plated mild steel.

#### MINIMUM & MAXIMUM SINGLE SECTION SIZE:

100 x 100mm minimum & 1200 x 1800mm maximum.

All manual dampers available with motorized option with Honeywell actuator

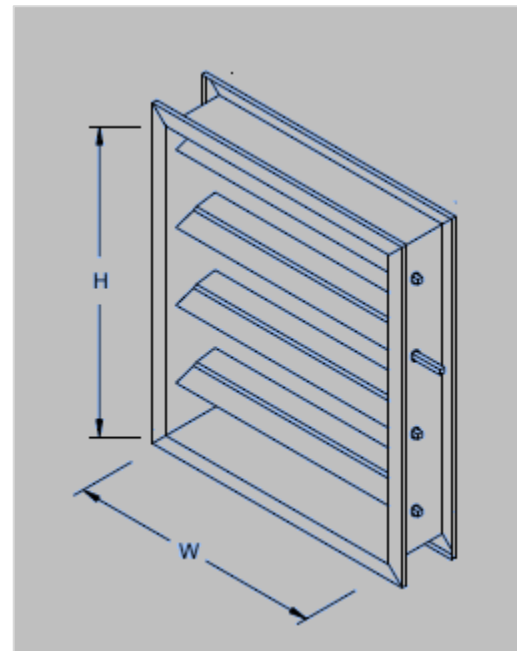

**FIRE RATED VCD**

**STANDARD CONSTRUCTION**

**FRAME:**

150mm x 25mm x 1 mm(20 G) galvanized steel formed channel for flange connection.

**BLADES:**

150 mm max. width, extruded aluminum aerofoil type blades.

**FINISH:**

Mill galvanized.

**LINKAGE:**

Side linkage concealed in frame for parallel and opposed blade operation.

**CASE BEARING:**

Bronze bushing for smooth and rattle free operation.

**CONTROL SHAFT:**

10mmx10mm & 12mmx12mm square zinc plated mild steel.

**MINIMUM & MAXIMUM SINGLE SECTION SIZE:**

100 x 100mm minimum & 1200 x 1800mm maximum.

All manual dampers available with motorized option with Honeywell actuator

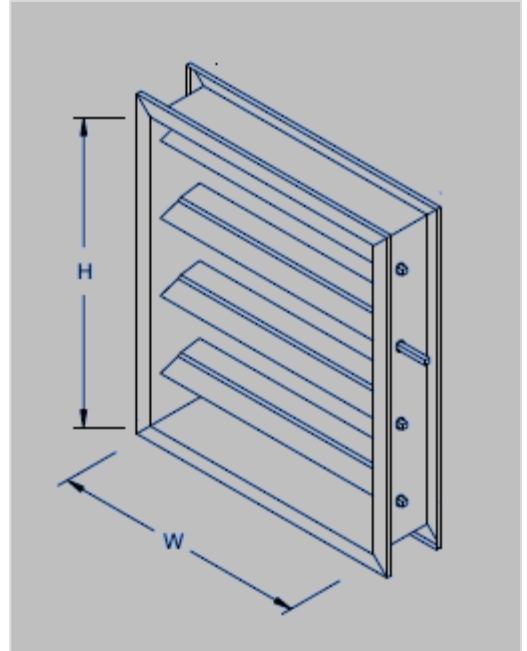

**DRIVE CLEAT DAMPER**

**STANDARD CONSTRUCTION**

**FRAME:**

150mm x 25mm x 1 mm(20G)  
galvanized steel formed channel for  
flange connection.

**BLADES:**

150 mm max. width, extruded  
aluminum aero foil type blades.

**FINISH:**

Mill galvanized.

**LINKAGE:**

Side linkage concealed in frame for  
parallel and opposed blade  
operation.

**CASE BEARING:**

Nylon bushing for smooth and rattle  
free operation.  
Brass bushing optional

**CONTROL SHAFT:**

10mmx10mm & 12mmx12mm square  
zinc plated mild steel.

**MINIMUM & MAXIMUM SINGLE  
SECTION SIZE:**

100 x 100mm minimum & 1200 x  
1800mm maximum.

All manual dampers available with  
motorized option with Honeywell  
actuator



**QUADRANT POSITION**

Height (mm)	Number of blades	Position of drive arm X(mm)
100	1	50
150	1	75
200	2	100
250	2	125
300	3	100
350	3	125
400	4	200
450	4	225
500	5	200
600	6	200
700	7	300
800	8	300
900	9	400
1000	10	400
1100	11	500
1200	12	500
1300	13	500
1400	14	600
1500	15	600
1600	16	700
1700	17	800
1800	18	900

Note: parallel and opposed blade dampers with flanged connection also available.

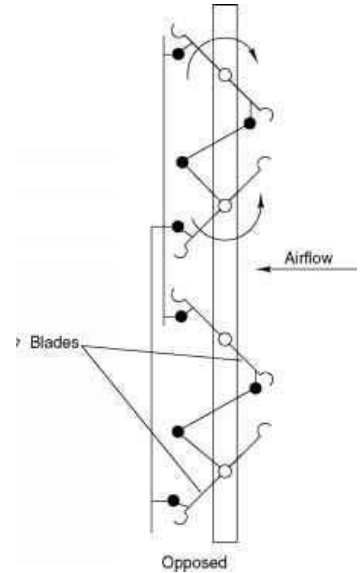

**SASVD-25-OB**

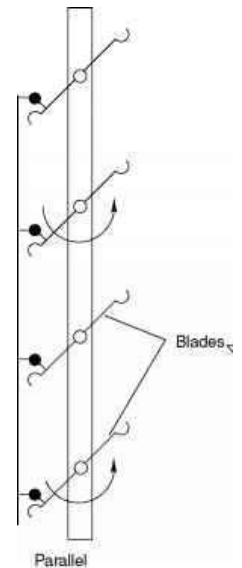

**SASVD-25-PB**

**BODY:**

Galvanized steel sheet.  
Gauge 20 : from Dia. 80mm to 400mm.  
Gauge 18 : above 400 Dia.

**BLADE:**

Plain galvanized steel sheet.  
Blades made of 18 G galvanized sheet.

**FINISH:**

Mill galvanized.

**CASE BEARINGS:**

Nylon bushing for smooth and rattle free operation

**CONTROL SHAFT:**

10x10 mm and 12x12mm diameter zinc plated mild steel.

**MINIMUM & MAXIMUM SIZE:**

80mm Dia. damper up to 600 Dia. are single blade construction.



**SIZE CHART**

Size (mm)	Length (mm)	Casing Thickness (mm)	Blade thickness(mm)	Axle & Bearing (mm)
100	120	1	1	10x10
150	170	1	1	10x10
200	220	1	1	10x10
250	270	1	1	10x10
300	320	1	1	10x10
350	400	1	1	12x12
400	450	1.2	1.2	12x12
450	500	1.2	1.2	12x12
500	550	1.2	1.2	12x12
550	600	1.2	1.2	12x12
600	650	1.2	1.2	12x12

**BODY:**

Galvanized steel

**Thickness:**

18 gauge

**BLADE:**

Plain galvanized steel sheet.  
Blades made of 18 G galvanized sheet.

**FINISH:**

Mill galvanized.

**CASE BEARINGS:**

Bronze bushing for smooth and rattle free operation

**FLANGE CONNECTION:**

Circular Flange

**CONTROL SHAFT:**

12x12mm diameter zinc plated mild steel.

**MINIMUM & MAXIMUM SIZE:**

80mm Dia. damper up to 600 Dia. are single blade construction.



**SIZE CHART**

Size (mm)	Length(mm)	Casing Thickness (mm)	Blade thickness (mm)	Axle & Bearing (mm)
100	120	1.2	1.2	12x12
150	170	1.2	1.2	12x12
200	220	1.2	1.2	12x12
250	270	1.2	1.2	12x12
300	320	1.2	1.2	12x12
350	400	1.2	1.2	12x12
400	450	1.2	1.2	12x12
450	500	1.2	1.2	12x12
500	550	1.2	1.2	12x12
550	600	1.2	1.2	12x12
600	650	1.2	1.2	12x12

OPPOSED BLADE DAMPER

SASVD-25-PB

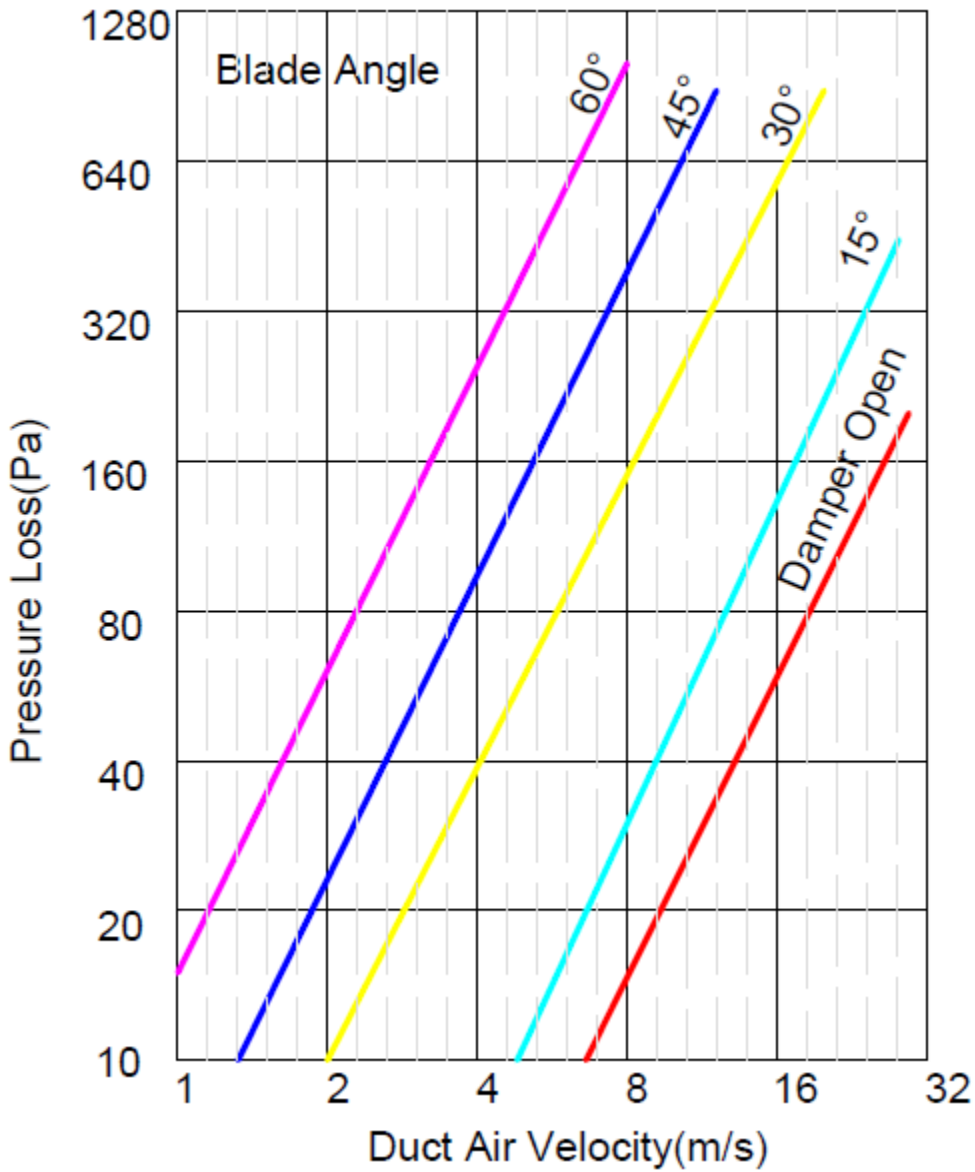

PARALLEL BLADE DAMPER

SASVD-25-OB

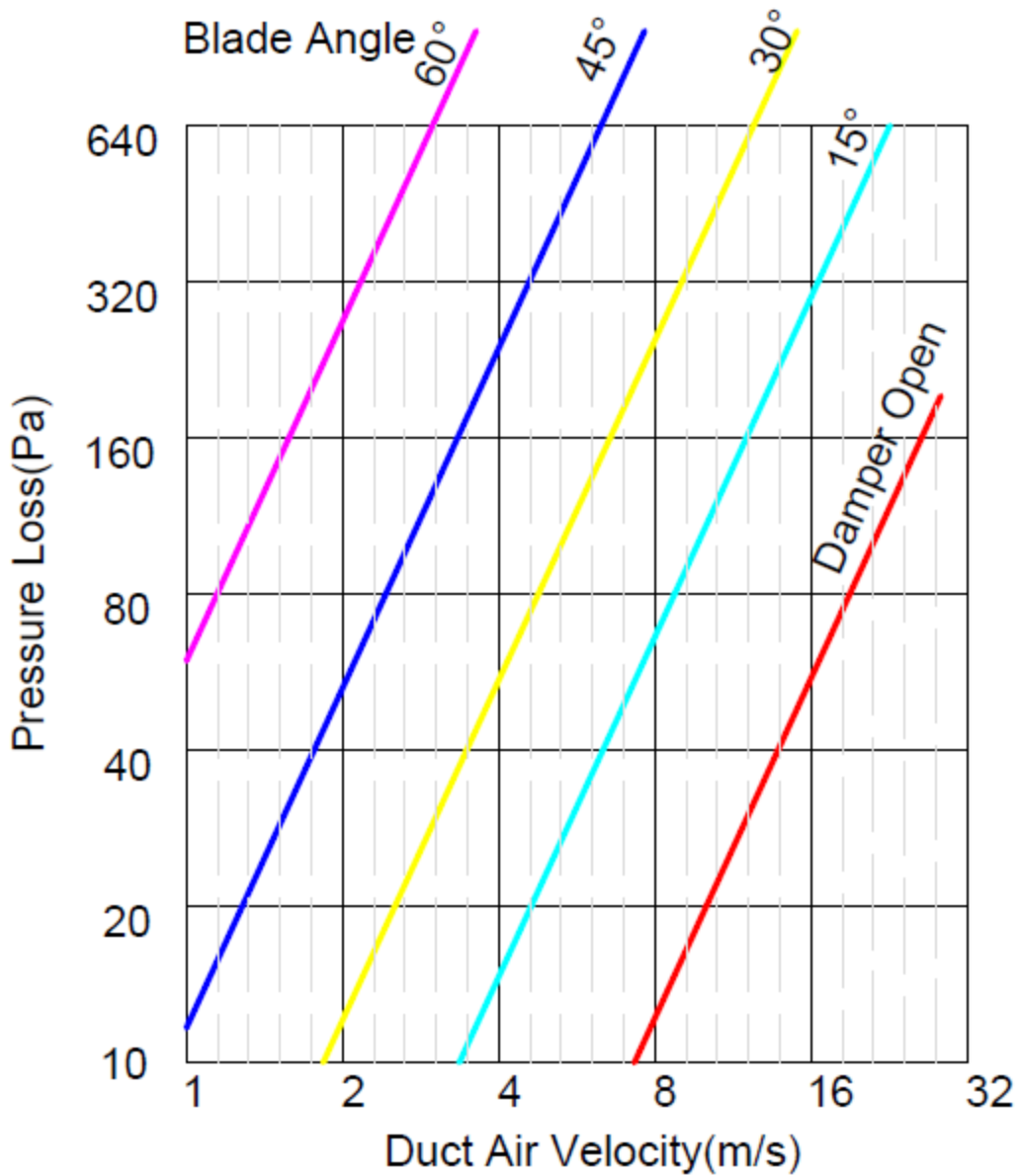





**AL MABANI**  
AL UMUMIYYAH